

INSTALLATION OF PALLET FIXTURE ON MACHINE TABLE

Barakaev Nusratilla Rajabovich

Doctor of technical sciences, professor

Odinaev Rustam Sobirovich

Probationer-teacher

Safarov Bekzod Kuzi ugli

Undergraduate

Bukhara Engineering-Technological Institute

Article history:	Abstract:
Received: 20 th April 2021 Accepted: 30 th April 2021 Published: 31 ^h May 2021	The article covers the option of installing pallet fixture of prismatic shape, where the required relative position of the pallet with the processed parts on machine table is carried out relative to cutting tool installed in the spindle of milling-boring machine with CNC.
Keywords: Milling-boring machine, PV machine table, machine layout, machine with CNC, pallet fixture.	

INTRODUCTION

Operation position with the use of automatically interchangeable pallet fixture of prismatic shape is assembled from normalized and aggregate units with CNC [1].

Ability to control performance parameters, to change the program of machined parts during the shift with ensuring operational reliability and changing the technological process is assured [2]. In this regard, the following opportunities appear:

1. partial change and transformation of the structure and layout of machine system, the structure of technological processes, the transformation of organization of production preparation;
2. change in organization of technological and transport flows with a change in structure of technological process and system of machines;
3. structural transformations and technical-operational solutions leading to control of concentration and differentiation processes in processing of products applied to various operating conditions;
4. possibility of variant, structural transformations, to change the nomenclature, and, accordingly, the program of products, the productivity of technological process and processes of the functioning of machine system, processing of products of variable nomenclature during several shifts of one calendar day is provided.

MAIN PART

Developed design of pallet fixture of prismatic shape in assembly (Fig. 1) can be used to perform multilateral machining by milling, boring, drilling of complex, including shaped surfaces of parts (limiting dimensions 300x300 mm) on CNC machines of various performance.

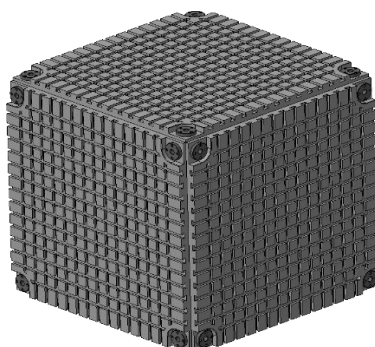

Fig. 1. Model of pallet fixture in assembly.

Illustrative example of the use of this kind of adjustments can be the operation of milling the key slot on Pittler PV 1600 machine with modifications 2-1P or 2-2P (made in Germany) [3] (Fig.2).

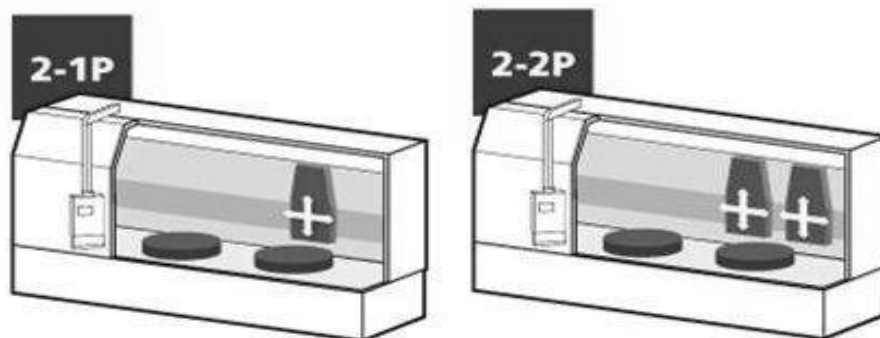

Fig. 2. Modifications of Pittler PV 1600 machine.

Modifications 2-1P and 2-2P differ in that the modification 2-2P has two spindles for simultaneous processing of several transitions.

This machine arrangement allows processing the parts in one workplace, while the operator fixes the parts on the second. After finishing the machining, the spindles move to the second working area, thereby freeing up the area with the machined parts for the operator. The operator removes the parts and installs new blanks in their places. After finishing processing in the second zone, the cycle is repeated. This approach to organizing work on operations is very convenient due to the compactness and continuous operation of the equipment, and the use of universal assembly device reduces the time for replacing the blank. A visual view of machine is shown below (Fig. 3).



Fig. 3. PV 1600 2-2P machine.

The pallet fixture, assembled with fixed parts, is installed on machine table (Fig. 4)

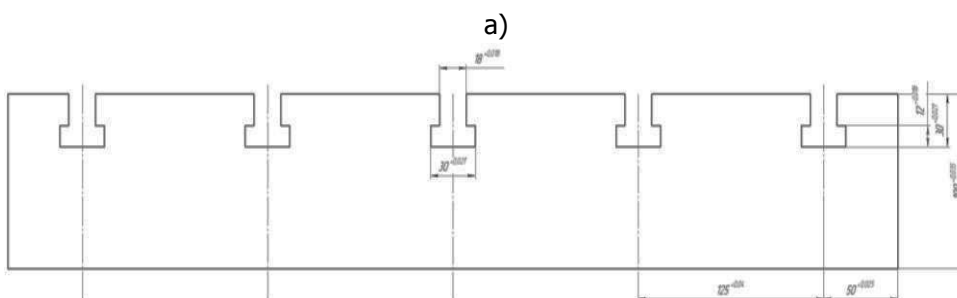

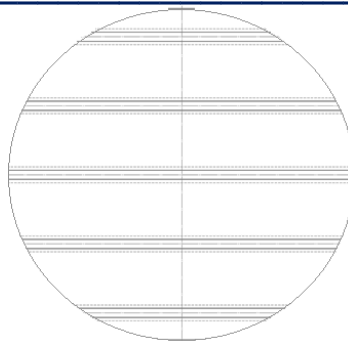

b)
 Fig. 4. PV 1600 2-2P machine table. a) side view, b) top view
 Table 1

Characteristics of PV 1600 2-2P

PV line with Y-axis	Unit	PV 16002-2P
Spindle flange diameter	mm	800
End bearing diameter	mm	670
Power at 100% use	kW	208
Torque at 100% use	Nm	23,400
Rotation frequency	min ⁻¹	400
Y-axis	mm	±300
Turning diameter	mm	1,600
Turning diameter without Y-axis	mm	2,000
Maximum part length	mm	500 (1000)
Maximum part weight	kg	5,000

The method with the use of standard and unified elements of universal-assembly devices is proposed as one of the options for installing a pallet fixture. In this case, cylindrical mandrels with locating pins (cylindrical and rhombic) are used as elements for basing the pallet.

Installation of the pallet fixture is carried out as follows. The pallet in assembly 1 is installed on the machine table 2 using clamps 3 and fasteners 4, 5, 6 (see Fig. 5). In this case, the clamping force P_3 of at least 1500N is transferred to the clamps 3 by means of the springs 7, so that the kinematic closure of the clamps 3 with the strips 8 installed by means of the M6 screws (pos. 9 in Fig. 49) and strips 10 in the T-shaped grooves of outer plates of pallet is ensured. The created force of the kinematic closing P_3 ensures the basing of pallet along the alignment pins of cylindrical 11 and rhombic 14 shapes. The locating pins 11 and 14, in turn, are pressed into bushings 12, which are installed in T-shaped grooves of machine table by means of strips 13.

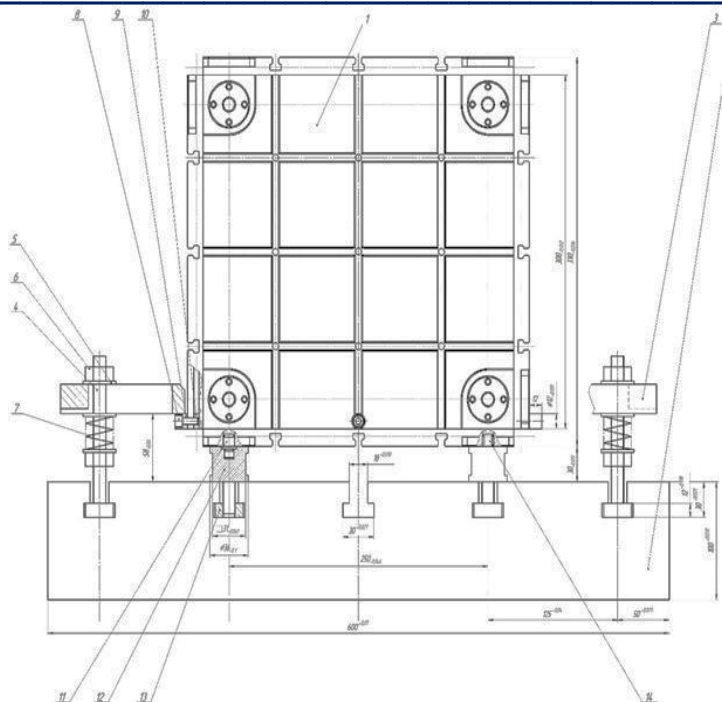

Fig. 5. Scheme of installing the pallet on machine table.

The mandrels 12 are set in advance along T-shaped grooves of machine table to the required center-to-center distance $L_m = 250 (-0.046)$ mm (see Fig. 22).

The model of proposed scheme for installing a pallet on machine table is given in Appendix G of the project.

According to the scheme proposed in the project, the pallet is reinstalled by relocating it along the alignment pins 11 and 14, alternating a set of two diagonal holes on each face of its body, after which it is also fixed with clamps 3 and fastening elements 4, 5, 6.

CONCLUSIONS

Thereby, according to the engineering problem of the project, the variant of installation of pallet fixture of prismatic shape is proposed, where during processing parts on machine according to CNC control program, the required relative position of pallet with the processed parts on machine table is carried out relative to the cutting tool installed in the spindle of milling-boring machine with CNC.

Application of devices that partially or fully combine the listed design features provides the ability to adjust performance parameters, to change the program of machined parts during a shift with ensuring operational reliability and changing the technological process

LITERATURE

1. Tabachnikov I.Z. Assembly-and-disassembly devices [Text] / I.Z. Tabachnikov, V.I. Yermilov, V.M. Freidenzon. Kharkov: Prapor, 1965, p. 67.
2. Anserov M.A. Devices for metal-cutting machines. –Leningrad: Mechanical engineering, 1975, p.656.
3. Pittler.de [Electronic resource]. Access mode: http://pittler.dvs-groupe.com/uploads/tx_xpctypedownloadssimlpe/PVSLN1_en.pdf (date of access: 10.05.2018).