



DESIGN OF THE EXPERIMENTAL UNIT AND PRINCIPLE OF OPERATION

**Behbudov Shavkat Husenovich.,
Yoqubov Muxriddin**

Bukhara Engineering and Technological Institute (Uzbekistan)

**Rakhimova Gulora Pirnazarovna.,
Matchanova Gulrukh Hayitmatovna.,
Mamatova Sayyara Shavkatovna**

Urgench State University, (Uzbekistan)

Article history:	Abstract:
Received: 10 th April 2021 Accepted: 26 th April 2021 Published: 27 th May 2021	The article describes the methods of applying composite materials to the surface; for conducting experimental research, a laboratory setup has been developed that allows measurements in real conditions. The scheme of an experimental installation for sewing tarpaulin cloths, the results of experiments on strengthening the stitching of tarpaulin materials are presented.
Keywords: Stitching, device, polymer, sealing, waterproof material, tensile machine, stiffness, riot, strength, rupture, tarpaulin, moisture.	

The purpose of the work was to increase the water-protective capacity of canvas fabrics for sheltering cotton riots from moisture by developing combined sealing technologies based on the use of modern water repellents and sealing materials.

Carrying out experimental studies is to determine the dependence of the influence of the parameters of the tarpaulin piercing, with the subsequent application of a composite material to it on the strength characteristics of the seam [1,2,3,4].

The main task in this context of solving the problem is the development of such technologies for sewing products of a high protective level of quality, which are harmoniously integrated into the sequence of operations of the tarpaulin sewing process.

To achieve this goal, the following scientific and technical problems were solved:

study of the influence of various factors (material, design of knots and thread connections, manufacturing technology and operating conditions) on the waterproof function of tarpaulin awnings;

development of requirements and rules for the harmonization of the processes of physical and chemical sealing and technology for joining tarpaulin with the creation of combined technologies for the production of tarpaulin canvases;

study of the effectiveness of the use of various hydrophobizing compositions and sealing materials for processing nodes and thread joints of tarpaulin of all types with waterproof properties;

development of technical devices and technologies for sealing tarpaulin awnings made of waterproof materials for various purposes, adapted to the conditions of traditional sewing processes;

development and research of technological processes that make it possible to implement the sealing treatment of tarpaulin within the framework of the possibility of its application in a cotton ginning plant;

development of methods and technical devices for determining the characteristics of the water-protective properties of units and joints of waterproof seams from a tarpaulin;

The task of experimental research is to determine the dependence of the change in the strength of the seam on the conditions for applying the composite to the material surface. [5,6,7].

Having studied the existing methods of applying composite materials to the surface, for conducting experimental studies, we developed a laboratory setup that allows measurements in real conditions.

A device has been created that assumes the implementation of a local technology for sealing the places of thread joints of parts of garments and tarpaulins, which have water-protective properties. It makes it possible to apply a liquid-phase polymer composition in the form of a continuous line in the direction of the thread line. Such a technical solution made it possible to obtain a sealed thread line with sufficient waterproof technological and aesthetic characteristics. In the presented work, an industrial prototype of an automated complex was designed for sealing the places of thread joints of tarpaulins, and a number of theoretical and experimental studies were carried out, giving a clear justification for the selected methods of eliminating the above disadvantages and allowing to evaluate the effectiveness of the created device.

With the required sizes of awnings for sheltering cotton riots, the sizes of awnings in the aisles of a square measuring 8m by 7m with a total area of 54 m² to 64 m² are mainly used, which will allow covering part of the riots with the subsequent connection of individual parts of the awnings into a common one.

With known values of the density of the tarpaulin material, let's say Article 1292SKPV, 11292 PV and 11293OP per square meter of fabric can reach up to 400g and the total weight of the awning can be, depending on the type of material in the aisles, from 24kg to 35 kg, which significantly complicates the technology of sewing and attaching cloths to each other. a friend on sewing machines.

Therefore, in production at cotton factories, in most cases, hand-sewn awnings are used in violation of the sealing technology. As you know, for sewing tents with large areas, special devices and devices are used on sewing machines, therefore, we were faced with the task of developing technology and devices for sewing tents from tarpaulin [8,9,10].

To ensure the continuous operation of the sewing machine and the technological process of sewing tarpaulin cloths, a feeding platform should be designed on rotating supports with a table with a table diameter of 2000 mm and installed close to the table by a sewing machine.

The diagram of the proposed design of the table and sewing machine is shown in Fig. 1.

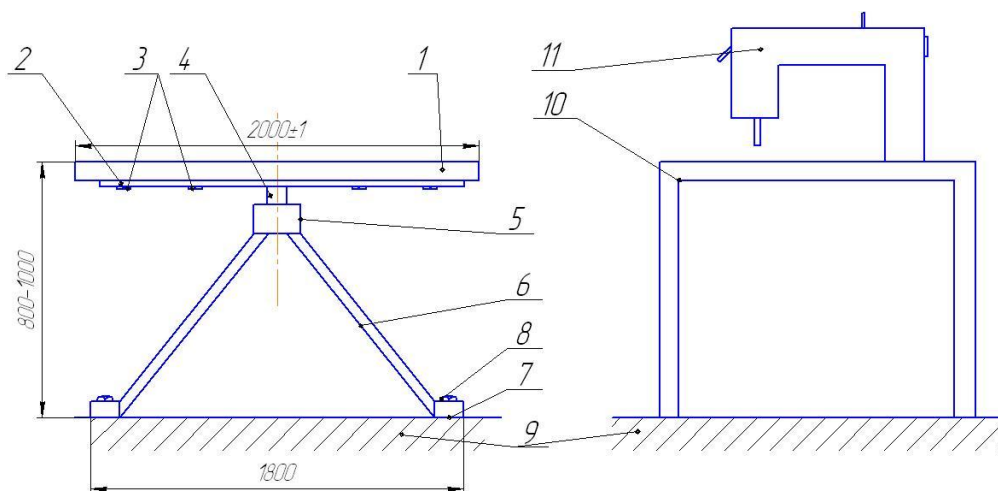

Fig 1. Diagram of an experimental installation for sewing tarpaulin cloths.

1- rotating table. 2- table frame, 3- stiffening ribs, 4- rotation axis, 5- controlled electric drive, 6- table stands, 7- anchor bolts, 8- fastening legs, 9- base. 10- sewing machine table, 11- sewing machine.

The experimental setup includes a TYPICAL sewing machine with standard parameters set by the factory. This sewing machine has a mechanism for moving the needle and rail and is a walking type of sewing machine designed for sewing heavy, dense materials. The sewing machine is double-row, the spacing between the lines is 6mm.

Also, to measure the parameters of the machine and the technological process, measuring elements and devices for applying a composite material at the junction of the materials to be sewn were installed on the sewing machine.

RESEARCH METHODOLOGY:

To study the performance of the proposed design of applying polymers in the sewing process, we analyzed the existing methods and methods of conducting experiments. From the analysis of the studies carried out to assess the performance of this structure, we have selected parameters that allow us to determine the effect of the selected parameter on the characteristics of the seam. The experimental results obtained were recorded on oscillograms and processed on a computer.

When carrying out experimental measurements to improve the accuracy of measurements and eliminate extraneous interference, the parameters were measured in idle running of the machine without load.

To test the strength of fabrics on a tensile testing machine, samples of 40 cm long and 3 cm wide were made, 10 samples of each version from KHAKI materials. Tarpaulin Small and large tarpaulin. In fig. 2 shows samples from these tissues.

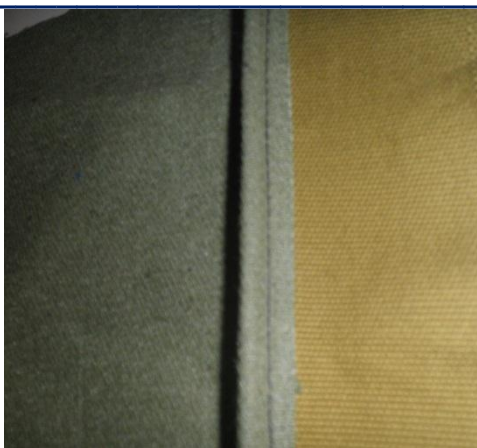

Fig. 2 Samples of fabrics to check for rupture.

A sample chart for recording the tensile tissue on a tensile machine for a tarpaulin sample. Article 11292SKPV, 11292 PV and 11293OP The table shows the tensile strength and% elongation of uncoated and coated fabrics.

Table 1 shows the average value of the results obtained from selected samples with a replication of 25 pieces. Without emulsion coating.

Table 1

Material.	Breaking force N.	Elongation of tissue in %
Khaki tarpaulin SKPV	68,8	15
Small tarpaulin PV	62,4	21
Large tarpaulin OP	42,4	14,4

The results of measurements of the strength of the fabric on a tensile testing machine.

Coating.	No coatings.		Emulsion PVC		Emulsion SELECON	
Tarpaulin material.						
Khaki SKPV	68,8	ud 15%	96,6	20%	109,4	15%
Small PV	62,4	ud 21%	72,8	17,4%	90,4	18,4%
Large OP	42,4	ud 14,4%	48,4	14,4%	49,2	14,2%

REFERENCES:

1. V.V. Veselov, I. D. Gorbunov, I. V. Molkova. A device for applying a liquid-phase polymer to cuts of cut parts. Proceedings of universities. Textile industry technology. - 2007, No. 3. 97-99.
2. V.V. Veselov, GV Kolotilova. Chemicalization of technological processes of sewing enterprises: Textbook / Edited by V.V. Veselov. - Ivanovo: IGTA, 1999.
3. Tashpulatov S.Sh., Dzhuraev A., Israilova B.G., Behbudov Sh.Kh. Patent.uz FAP00917 dated 04/11/2013 A device for applying a polymer composition to the worn parts of clothing.
4. Mansurova M.A., Djuraev A., Behbudov Sh. H., Tashpulatov S.Sh. Mathematical model of dynamics of device for applying polymer composition on grind parts of the clothes. European Sciences review Scientific journal № 11–12 2016 (January–February) 129-131
5. Safronova I.V. Technical methods and measuring instruments in the clothing industry. M., "Light and food industry", 1993
6. Ermakov S.M. Mathematical theory of the optimal experiment [Text] / SM Ermakov, AA Zhiglevsky. -M .: Nauka, 1987.
7. Behbudov Sh.H., Mustafoyev K.I., Bozorova F.M., A.R.Amonov. "Analysis of studies of the angular movement of the lever rails in sewing machines" International journal of advanced research in science, engineering and technology. Vol. 7, Issue 4, April 2020. ISSN:2350-0328. India-2020
8. Behbudov Sh.H., Mustafoyev K.I., Bozorova F.M., A.R.Amonov. "Kinematic analysis of a closed lever-articulated mechanism for moving material of a sewing machine " International journal of advanced research in science, engineering and technology. Vol. 7, Issue 4, April 2020. ISSN:2350-0328. India-2020
9. Behbudov Sh.H., A.Dj.Djurayev., A.R.Amonov., D.X.Qodirova. "Teoretiko-experimental method of definition of parameters of the roller with the rubber plug of the device for drawing of the polymeric composition on lines of sewed materials" International journal of innovative tehnology and exploring engineering. ISSN:2278-3075, Volume-9 Issue-1, November 2019.

10. Behbudov Sh.H., A.R. Amonov., N.U. Latipova., M.Zh. Shodmonova. "Influence of the reduced stiffness of the elastic roller sleeve and the worn-off parts of clothing on the natural frequency of vertical vibrations of the rubber roller axis" Internauka Scientific journal No. 6 (88) February 2019. Part-1, Moscow.