

DEVELOPMENT OF TECHNOLOGICAL REGULATIONS FOR PRODUCTION OF LAMELLAR KNIVES USING EXPERIMENTAL INSTALLATION

Barakaev Nusratilla Rajabovich

Doctor of technical sciences, professor

Urinov Nasillo Fayzilloevich

Candidate of technical sciences, associate professor

Sohibov Ibodullo Adizmurodovich

Doctoral student

Bukhara Engineering-Technological Institute

Article history:

Received: 10th April 2021

Accepted: 26th April 2021

Published: 27th May 2021

Abstract:

The article covers complete technological procedure for production of knives, developed based on an analysis of the results of laboratory research of cutting process of food materials with cutting plates of various configurations, as well as an installation for the preparation of thin lamellar knives.

Keywords: Sharpening, cutting edge, knife holder, grinding wheel, grain size, blade microgeometry, durability, experimental plant

Production experience of rusks enterprises shows that the existing thin lamellar knives used in A2–XR–2P, XRO–M, and R3–XRC machines require significant tension. This reduces the durability of labor bodies, and causes deformation of fasteners. When the tension is released, lateral deflection of the cutting edge appears due to the insufficient working rigidity of the thin lamellar knives. The resulting wedge-shaped slices or wavy side surfaces of the workpiece make it difficult to ensure uniform drying of the product, often lead to the formation of rejects in terms of the color of the sides of the rusk.

The production tests involved knives made of U8 tool steel, having a hardness of 44-46 HRC, with the following geometric parameters: length $l = 250$ mm, blade width $B = 15$ mm, relative eccentricity of the tension line $\varepsilon = 0.2$, sharpening angle of the cutting edges $\alpha = 16^\circ$, blade length $l_1 = 200$ mm. Considering the peculiarities of the organization of work of repair services of food enterprises, the device for sharpening and finishing knives was made in the form of easily removable unit mounted on universal turning machine. The layout of the assembly units of the experimental device for forming the blades of thin lamellar knives is shown in Fig. 1. Grinding or lapping wheel with the help of bushings and nuts is fixed on a horizontal mandrel shaft (Fig. 2). One end of the shaft is mounted in a three-jaw chuck of the spindle, and the other is abutted by a rotating center [1]. The knife holder, shown in Fig. 3, is mounted in the tool holder of the machine. The design of the knife holder provides for a constant sharpening angle equal to 16° .

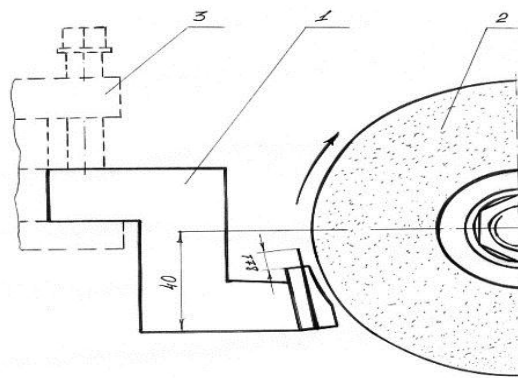

Fig.1 Experimental installation for preparing thin lamellar knives for work. 1- knife holder; 2- sharpening shaft; 3- machine cutter holder.

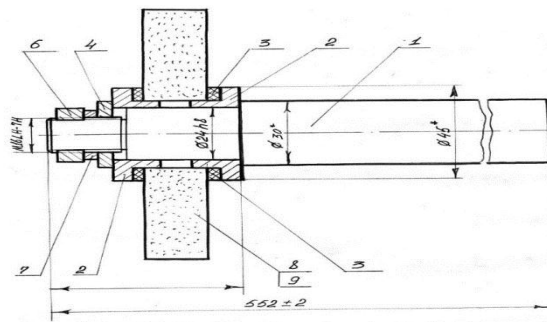

Fig. 2. Sharpening shaft of the experimental installation.

1 - mandrel shaft; 2 - bushings; 3 - gaskets; 4- washer; 6 - nut M16; 7 - bushing; 8 - grinding wheel; 9 - finishing circle.

Research results allow recommending grinding wheels with grain size 6 or 10, hardness M1 and M2 for sharpening lamellar knives with obligatory finishing with a leather wheel.

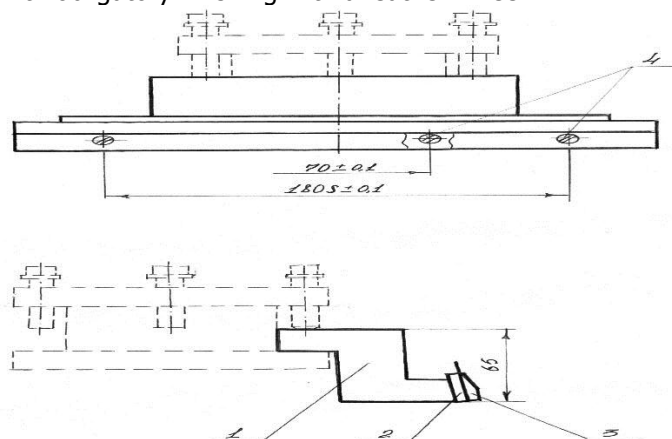

Fig. 3. Knife holder: 1- case; 2- body plate; 3- consignment plate; 4- screws.

The use of this device allows improving the quality of sharpening of lamellar knives, which resulted in an increase in their cutting ability and durability period, as well as reducing manual labor in this operation and its duration, and reducing the consumption standards for materials for knives production. The knives used on this device have a predetermined sharpening angle throughout the blade and have high technological reliability. [2] Technological regulations for knives production are developed based on analysis of the results of laboratory studies of process of cutting food materials by cutting bodies of various configurations, and tested in production conditions.

Knife parameters. Research results have shown that the geometric parameters of thin lamellar knives for cutting rusks should have the following values: sharpening angle 15–17°, knife width 10–15 mm, thickness 0.4–0.5 mm, length 250 or 330 mm (for cutting rusk plates, depending on the type of machine), triangular notch on a blade with a depth of 2-3 mm, with a step of 10-12 mm, and apex angle 60°.

Workpiece. For the knives production, high-quality carbon or alloy steel U8-10A in the form of a tape with a thickness of 0.4 mm and a width of 10-15 mm is used. The strip on a horizontal machine is cut into pieces equal to the length of the knives used in a particular cutting machine (for machine of the XRP-250 mm type, XRO-330 mm). The right angles of the resulting workpiece are rounded on emery to a radius of 3-4 mm. The surface finish of the workpiece must be at least the seventh grade. Varying of workpieces is not allowed. The thickness twist should not exceed 0.05 mm, and the unevenness of the workpiece width should not exceed 0.3 mm along the entire length.

Making mounting holes. Displacement line is applied in the extreme zones of workpiece, which is spaced from the longitudinal axis by 1–2 mm (depending on the original width of the tape), towards the future cutting edge, to ensure its relative eccentricity $\varepsilon=0.2$.

Riffling. Points are marked on the long side face of the workpiece, which are spaced from each other at a distance of 10-12 mm with a constant step. After fixing the workpiece (or a package of workpieces of 8-10 pcs.), notch with 2-3 mm depth with an apex angle of 60° is applied at the marked points.

Heat treatment. For heat treatment of lamellar knives, the quenching with heating to $t = 740^\circ \text{C}$ and cooling in oil is recommended. Hardness control must be carried out on a device of the PMT-3 type.

Sharpening. Sharpening and finishing operations are performed on special device (see Fig. 1), which is mounted on any universal turning machine with a center height of at least 150 mm. A knife holder is fixed in the tool holder of the machine so that the protruding edge of the base is parallel to the longitudinal axis of the sharpening shaft. The knife workpiece is installed and secured between the front and rear strips. After sharpening the workpiece on one side, it is turned over and the other face (chamfer) is sharpened.

Sharpening modes: grinding wheel EB25M2K; peripheral speed 12-15 m/s; cross feed (cutting depth) 0.04 mm; longitudinal feed 0.6 m/min. After sharpening each side, the knives are "raised" (without cross feed) within 3-4 double strokes of the knife holder. Because of sharpening, the knife has a sharpening angle of $16+1^\circ$, and the width of the cutting edge is 5-8 microns. [3]

Finishing (setting). Finishing reduces the width of the cutting edge to 2-4 microns and ensures optimal topography of the blade microrelief. For finishing, a wheel made of electrocorundum with grain size 6, hardness CM2, or a grinding wheel made of elbor is installed on the grinding shaft. It is also allowed to install a circle made of electrocorundum on a ceramic bond of the same grain size and hardness. Cutting depth is 0.005 mm. Sharpened knives should be pre-wiped with a soft cloth, and then washed with hot water with 1-2% soda ash and wiped dry. If the knives are not placed in the knife frame, they must be preserved in the usual way.

Control. In production conditions, quality control of sharpening and finishing of each knife is carried out by visual inspection according to the following indicators: straightness of the cutting edge; lack of twists, burrs and chipped sites on the blade; no staining and sanding cracks on the chamfer.

Installation of knives. The knives are mounted in the knife frame in the usual way. It is recommended to tension them consistently in the direction from the edges to the middle of the frame. The magnitude of the pulling force should be reduced in comparison with the previously applied ones.

Compliance with the requirements of this regulation provides an increase in the durability period of thin lamellar knives by several times, a reduction in cooling and holding of rusks to 0.5-1.0 hours, an improvement in cut quality, a decrease in return waste in the form of crumbs and deformed slices. The design of the machine (fastening and tension of knives, cutting and feeding modes) does not need any changes.

LITERATURE

1. Baykalov A.K. Introduction to the theory of grinding materials. Kiev: Naukova Dumka, 1978, p. 207.
2. Blinov A.V. Improving the process of sharpening cutting tools for sausage production. Abstract of candidate dissertation. Moscow: Moscow State Academy of Applied Biology, 1995, p. 24.
3. Mutsianko V.I. Fundamentals of choosing grinding wheels and preparing them for use. Leningrad: Mechanical engineering, 1987, p. 134.